

Ways to improve quality of the inclusive clothing designing process

Tatyana Aleksandrovna Zaytseva
The Department of design and technologies
VSUES
Vladivostok, Russia
zai-tanya@yandex.ru

Liudmila Anatolyevna Koroleva
Department of design and technologies
VSUES
Vladivostok, Russia
ludmilaakoroleva@gmail.com

Olga Vladimirovna Panyushkina
Department of design and technologies
VSUES
Vladivostok, Russia
panyushkina.olga@mail.ru

Irina Anatolyevna Slesarchuk
Department of design and technologies
VSUES
Vladivostok, Russia
slesarchuk65@mail.ru

Abstract— The article reveals the issue of improving the quality level of the automated process of designing inclusive clothes. The complexity of designing this type of clothing as a multifunctional facility is associated with the need to take into account a set of special requirements that allow to level out the everyday clothes of a healthy person and clothes of a person with various disabilities and health abnormalities.

Our review of existing methodologies in the field of structural analysis of system objects has showed that the process-oriented methodology of information system design, based on IDEF-technologies (standards), should be used to improve the quality of project solutions. We have performed a CAD-simulation using this technique on the basis of the generally accepted sequence of design stages, taking into account the identified factors that determine the choice of requirements for inclusive clothing for people with musculoskeletal disorders. In addition, we have identified the factors that determine the choice of requirements for inclusive clothing for people with musculoskeletal disorders. Also we proposed the principles for evaluating the quality of design solutions for inclusive clothing.

The obtained model of the automated process of designing inclusive clothes based on the IDEF0 standards has been tested as an example of trousers for men using a wheelchair. The gradual assessment of the quality of design solutions has shown a high level of inclusive clothes quality with a significant reduction in the material consumption, time and labor intensity of work at all stages of design.

Keywords—*component; formatting; style; styling; insert (key words)*

I. INTRODUCTION

According to the World Health Organization (WHO), there are more than a billion people are living with some form of disability in countries around the world; of which almost 200 million have serious operational difficulties.

The prevalence of disability, including musculoskeletal disorders (MSD), will increase steadily in the coming years due to the progressive processes of population aging, the increase in the number of victims of road accidents, the global growth of the main diseases of the century, according to experts [1]. An emergence of disability of this kind means a limitation of life activity, which often leads to conflict with the surrounding urban environment, which is not adapted to the needs of the low-mobility population groups.

Increasingly, the term "barrier-free" environment is used with regard to people with disabilities, implying in addition to the availability of known devices that facilitate movement and appropriate clothing that can enhance activity, confidence in self-reliance, and self-esteem of people lacking full-fledged motor functions.

In modern design, including clothing, there has been a tendency to promote inclusion, i.e. rejection of the so-called "segregation approach". Now a disabled person needs not just comfortable clothes, but clothes which erases the boundaries between healthy people and those who have disabilities, which makes it possible to look on par with healthy people, regardless of an existing pathology.

Currently, lack of inclusive clothing, adapted to the needs of people with MSD, in the Russian domestic market is one of the significant barriers to the integration of disabled people into modern society. This is due to considerable difficulties in creating such complex multifunctional objects as inclusive clothing.

It is necessary to simultaneously consider the whole set of requirements characteristic for clothes of a healthy person and with various violations and deviations in health at all stages of design. Lack of a systematic approach to the design of inclusive clothing as a single complex or means of the interrelationships between people, rehabilitative devices (RD) and the environment makes it impossible to obtain high quality products that meet all the specific requirements of the customer.

As a result of the review of scientific literature in the field of designing inclusive clothes for people with MSD, we have found out that a fairly great positive experience of the system design of indoor, special, therapeutic and hospital clothing had already been accumulated.

Existing studies on the design of clothing for people with MSD are mainly aimed at solving particular problems in developing the finding of individual design solutions [2-5]. V.M. Volkova, [6] N.Y. Savel'eva, [7] T.A. Zaitseva and I.A. Slesarchuk [4] considered the problem of the generation of requirements for the development of special clothing for various contingents of people with disabilities. However, these researchers did not address the issues of improving the quality level of such clothes during the design process in their works.

E.B. Koblyakova [8], V.E. Romanov [9], L.P. Shershneva [10] E.Y. Surzhenko [11], and Z.S. Chubarova [12] solved the problem of the quality formation and the quality control of indoor and special clothing on the basis of a systematic approach in their works. O.N. Kharlova's researches [13] are devoted to the methods of hospital clothing quality formation. However, in these works, the problems of quality control of clothing for people with MSD were not considered.

The scientific works of G.I. Surikova, V.E. Kuzmichev [14] and others are devoted to the computer-aided design (CAD) of general-purpose clothing.

Thus, issues related to improving the quality of the process of designing inclusive clothes for people with MSD using a CAD have not been solved yet.

Review of the literature in the field of large-scale systems research [15,16] has shown that by limiting the opportunities for their experimental study is advisable to use a process-oriented methodology for the design of information systems, based on the IDEF-technology (standards). This methodology is effective for the functional analysis of the stages of a CAD at the conceptual level and consists of a set of methods, rules and procedures, intended for construction of a functional model of an object in any subject area, for example, designing clothes for people with MSD.

L.A. Koroleva, O.V. Panyushkina, and A.V. Podshivalova have made functional modeling of outdoor clothing for healthy people [17,18].

II. FORMULATION OF THE PROBLEM

A. Purpose of the study

To improve the quality level of the inclusive clothing CAD for people with MSD by developing a functional process model.

B. Tasks

To systematize the initial information describing the problems of vital activity of disabled people.

To formulate principles for the quality control of design solutions based on clothing requirements for people with MSD.

To identify the content of the stages of the inclusive clothing CAD, providing the quality control of decisions taken at each stage.

III. THEORETICAL PART

The aim of using IDEF0 for new systems, which include the inclusive clothing CAD, is to define requirements and specify functions for the subsequent development of a system that meets the specified requirements and implements the assigned functions. The first level block displays the whole system (Figure 1). The title in the block (inclusive clothing CAD) is common to the whole model and is present on all following diagrams.

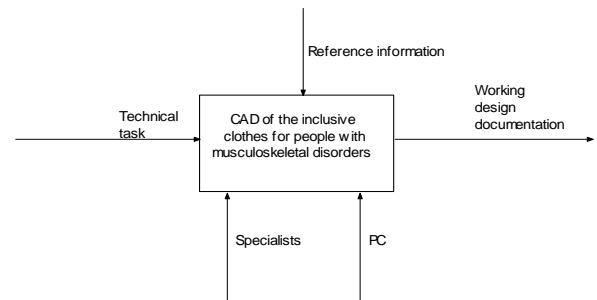

Figure 1 - The inclusive clothing CAD IDEF0-model's FEO diagram (level 1)

The data that is intended to control the execution of a system or block function, or set limits on its execution, enters the block from the top. These functions are implemented in this process according to the reference information. On the right side of the block are the results of the function - working design documentation (WDD). Means (specialists, technical devices (PCs), programs, etc.), using which the functions are performed, are represented by arcs entering the block from below. On the left side, the input information, which consists of technical task for development of the WDD, enters the block.

In the second-level diagram (Figure 2), the decomposition of the inclusive clothing CAD is presented in accordance with the generally accepted stages of design work [17]. The feature of this simulation is to implement the quality control procedures, management decisions and perform quality rating of the clothes been designed at each stage. These procedures are carried out in accordance with consumer, technical and economic indicators of quality. The quality of the design solution at the stage of the working documentation is rated by a complex generalized indicator determined by one of the methods adopted in qualimetry [8].

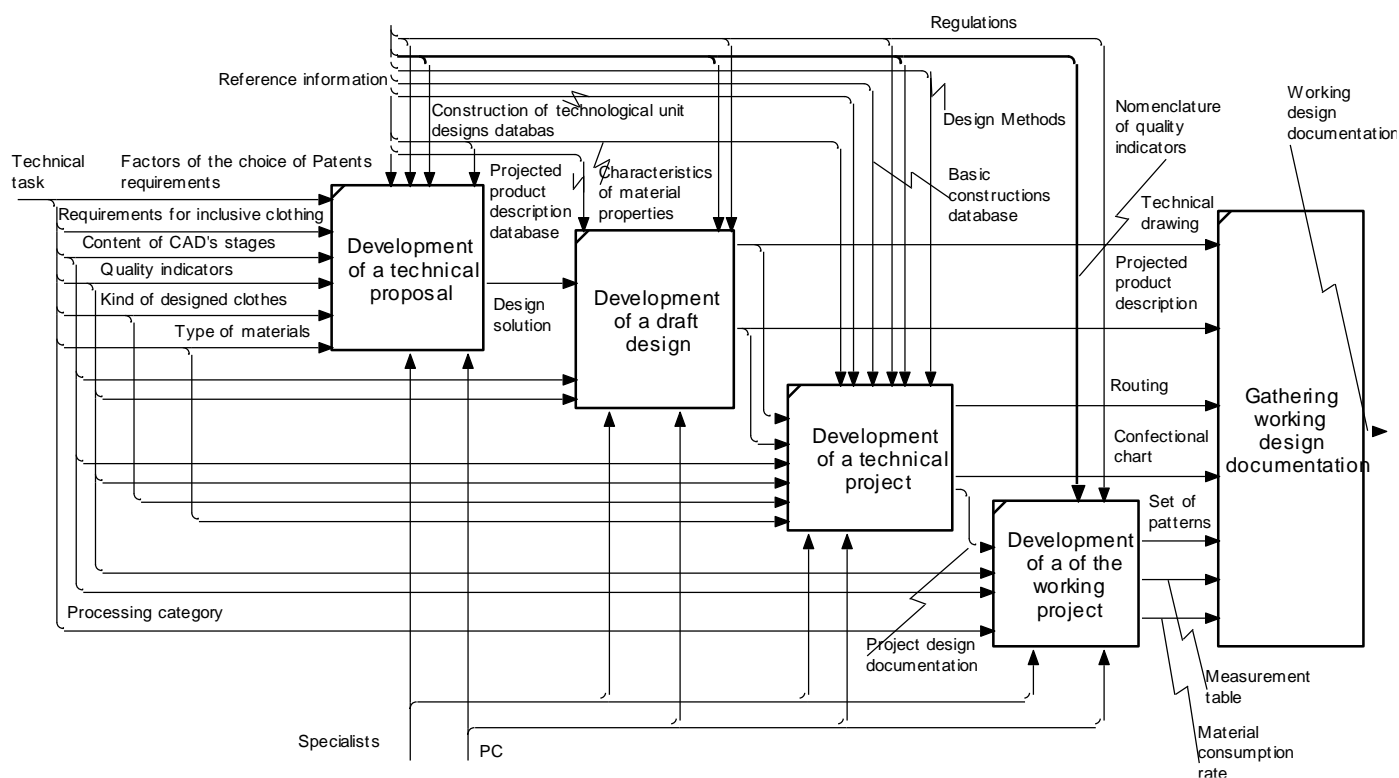

Figure 2 The inclusive clothing CAD IDEF0-model's FEO-diagram (level 2)

Учет особенностей жизнедеятельности людей с ОСДФ осуществляется при формировании ТЗ. Полученная информацией является входной для функционирования всех этапов АПП [18-21].

The vital activity features of the people with MSD are considered during the generation of technical task. The received information is used as an input for all stages of the CAD [18-21].

We have studied the vital activity features of the people with MSD to identify the factors that determine the requirements for inclusive clothing [4]. The result of the systematization is shown in Figure 3.

The factors we have identified determine the selection of consumer requirements for inclusive clothing, which include functional, ergonomic, operational, aesthetic, medical and social requirements.

The functional requirements express the compliance of the product to the main functional purpose, which, first of all, is determined by the compliance of the product to the modern way of life, and to the specific situation of the vital activity of the disabled persons.

The ergonomic requirements are the most significant for this type of clothing and are associated mainly with physiological changes in the body of people with MSD under a certain type of pathology.

Since the clothes of a disabled person which uses RDs (prosthesis, crutches, etc.) or stays mostly in a sitting posture during the day, experiences much heavier wear of the materials and structural elements compared to conventional clothing, operational requirements for the reliability of such clothing are increased. In addition, these are requirements for durability of seams, materials, and fastener's design.

According to the research [6], it is advisable to distinguish medical and technical requirements into a special group of requirements for people with MSD, which establish the possibility to provide partial or complete independence from the services of others when interacting with clothing, to facilitate the actions of persons involved in caring for disabled people, and to prevent development of morphological deformations. This group of requirements also includes requirements for ensuring the safety of the clothing design in places of contact with the RDs (e.g. requirements to eliminate the risk of jamming parts of clothing in the working parts of the wheelchair, prosthetics, etc.). The quantity of wrinkles and seams should be minimal to prevent inflammation that may occur as a result of wearing ordinary clothes, which was not adapted for people with MSD. This also will prevent damage to the skin when the body is contacting the joints in places of constant contact with the RDs.

An important role in the life of people with pathology that deprives them of the opportunity to move, but does not deprive them of active lifestyles and socialization, play aesthetic requirements. The feature of the inclusive clothing

composite solution development, which meets modern fashion trends, is to consider and hide morphological defects, for example, atrophied lower limbs.

The social requirements provide active involvement of disabled people in public life, which is especially important when creating inclusive clothing.

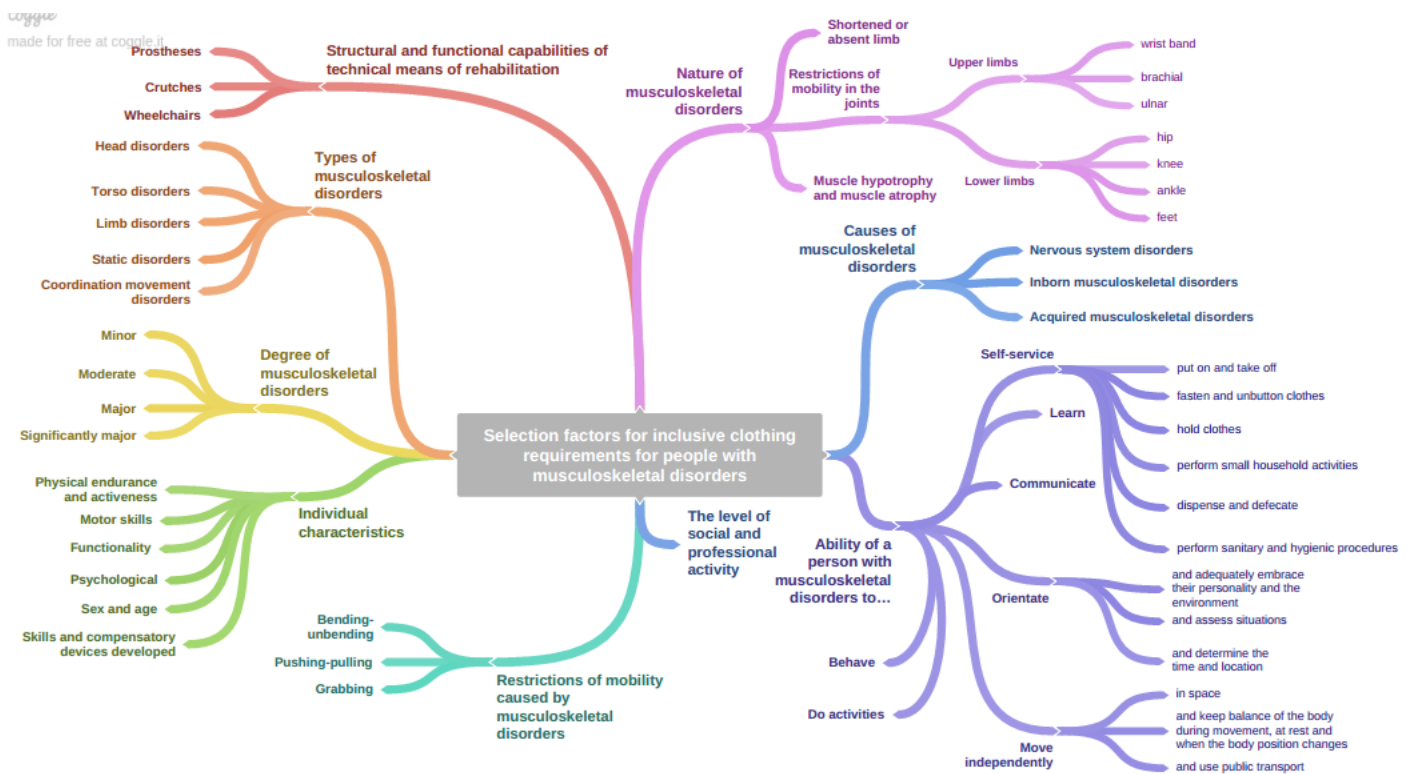

Figure 3 - Scheme of selection factors for inclusive clothing requirements for people with MSD

As a result of detailed analysis of these requirements, we have developed a multi-level, hierarchical structure of clothing quality indicators for people with MSD, providing the required level of quality in the stages of the CAD (Figure 4). Also, we have shown logical interrelations between the quality indicators of inclusive clothing and design procedures at the stages of CAD, demonstrated by the example of the most important group of medical and technical indicators for people with MSD (Figure 5). This allows to affect the quality of the design in the intermediate and final stages.

In this way, the results of modeling the inclusive clothing CAD based on the IDEF0 standards make it possible to implement a comprehensive quality control of the design process, providing selected level of quality. In result, we have developed the functional model of the process of inclusive clothing CAD, and shown the generation and movement of data between the stages of the CAD at a qualitatively new higher level.

Results of implementation

We have created inclusive clothing models of various assortments, experimentally tested in real conditions of use by people of middle and older age in a wheelchair. In result, we have received positive feedback. Also, we have

presented a special clothing line for low-mobile citizens at Fashion Week (VSUES, Vladivostok) within the "Accessible Environment" program, which aim is to create comfortable living conditions for people with MSD [22]. Furthermore, we have designed costumes for the performance "Following the Blue Bird" by the request of the Autonomous non-profit organization "Good deed" [23]. In addition, we have implemented patentable solutions of belt samples that allow us to improve the quality of inclusive clothing at each design stage due to a comprehensive consideration of the vital features of people with MSD [24, 25].

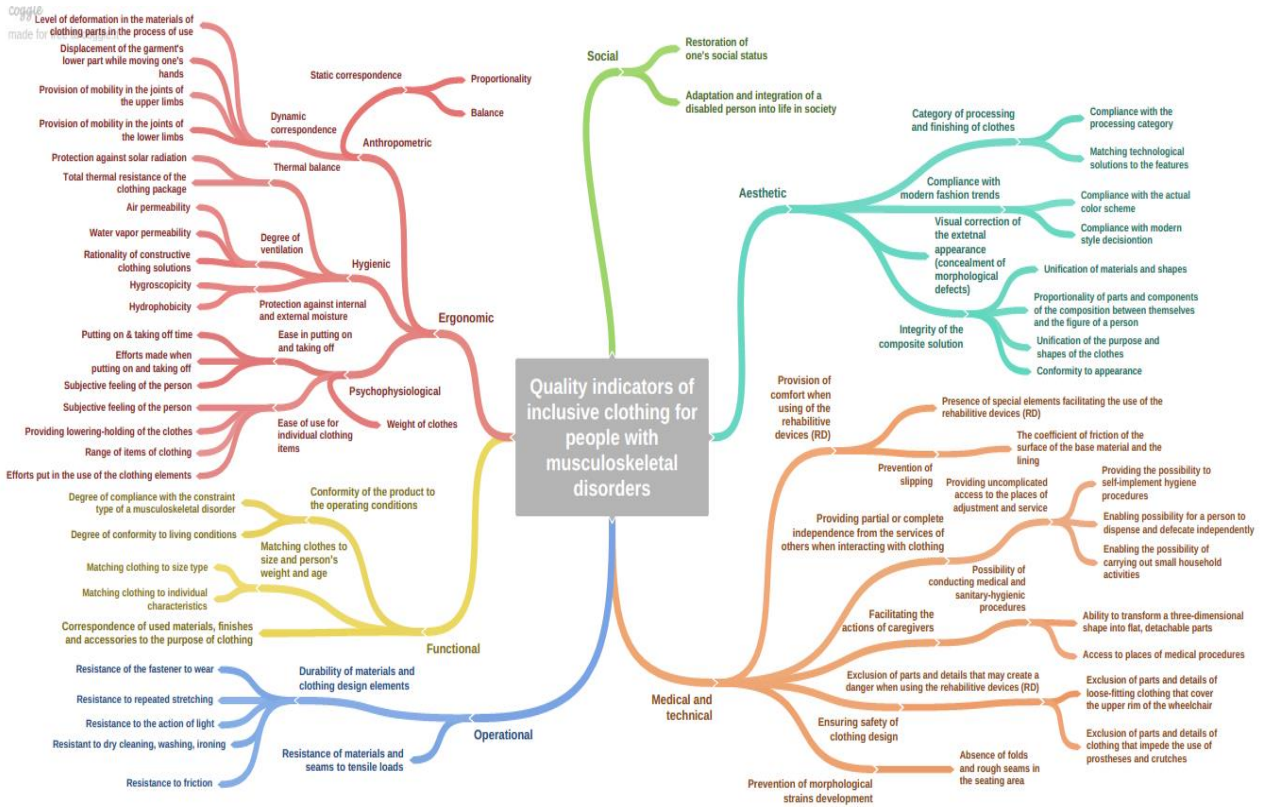

Figure 4 - Hierarchical block scheme of the consumer quality indicators of inclusive clothing (for people with MSD)

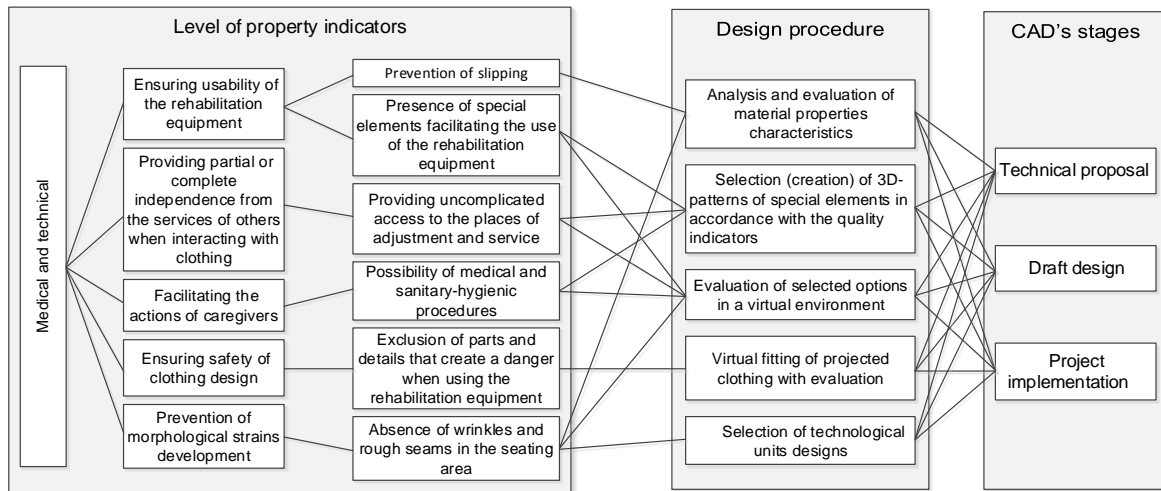

Figure 5 - Interrelation of quality indicators of inclusive clothes and design procedures at stages **CAD**

Conclusions

We have defined the factors of selection requirements for inclusive clothing for people with MSD, which determine the nomenclature of requirements.

Also, we have generated requirements for inclusive clothing for people with MSD, ensuring the quality and functionality of design solutions at all stages of design.

Then we have presented the principles for quality control of design solutions at each stage of the inclusive clothing CAD.

In addition, we have defined the composition and content of the stages of the CAD of clothing for people with MSD, which provide the quality control of decisions taken at each stage.

Furthermore, we have defined the interrelations between the quality indicators and the design procedures of the CAD,

which affect the quality of the project in the intermediate and final stages.

The creation of a functional model of inclusive clothing CAD allows to better understand the principles of making design decisions and improve the efficiency and quality of the process of designing clothes for people, considering the features of their life. This study will allow to realize further decomposition of the CAD stages.

References

- [1] Всемирный доклад об инвалидности Резюме на русском языке - Всемирная организация здравоохранения, Всемирный банк, 2017 г.
- [2] Приходченко, О.В. Разработка и исследование адаптационной одежды для людей с ограниченными двигательными возможностями: автореферат дис. ... канд. техн. наук: 05.19.04 / О. В. Приходченко. - Шахты, 2007. - 28 с.
- [3] Мельникова Р. А. Разработка метода проектирования одежды для реабилитации детей с нарушениями опорно-двигательного аппарата: автореф. дис. ... канд. техн. наук 02.19.04/ Р.А. Мельникова. - М., 2009. - 25 с.
- [4] Зайцева Т.А., Проектирование поясной одежды с улучшенными эргономическими показателями для людей с ограниченными двигательными возможностями // Т.А. Зайцева, И.А. Слесарчук, О.Н. Данилова // Современные проблемы науки и образования. – 2015. – № 2; URL: <http://www.science-education.ru/129-22871>
- [5] Розанова Е.А., Драгалина А.М. Выбор проектного решения при разработке одежды для людей с ограничением по здоровью/ Современные проблемы науки и образования. – 2015. - № 2 (часть 2). – Электронный ресурс: [<http://www.science-education.ru/129-23062>]
- [6] Волкова В.М., Голубева Ю.Б. Формирование требований к разработке специальной одежды для различных контингентов инвалидов с ограничениями жизнедеятельности/ В.М. Волкова, Ю.Б. Голубева // Издательство: Медико-социальная экспертиза и реабилитация, 2015. - 4с.
- [7] Савельева Н.Ю. Определение требований к специальной одежде для людей с ограниченными возможностями/Н.Ю. Савельева, О.В. Приходченко//Швейная промышленность, 2006. №5 –С. 35-36.
- [8] Коблякова Е.Б. Конструирование одежды с элементами САПР/ Е.Б. Коблякова. - М.: Легкая промышленность, 1988. - 464 с.
- [9] Романов В.Е. Системный подход к проектированию специальной одежды / В.Е. Романов. – М.: Легкая и пищевая промышленность, 1981. – 128 с.
- [10] Шершнева Л.П. Конструирование одежды: Теория и практика: Учебное пособие / Л.П. Шершнева, Л.В. Ларькина - М.: ФОРУМ: ИНФРА-М, 2006. – 288 с.
- [11] Сурженко Е. Я. Теоретические основы и методическое обеспечение эргономического проектирования специальной одежды: автореферат дис. д-ра техн. наук / Е. Я. Сурженко. - М., 2001. - 49 с.
- [12] Чубарова З.С. Методы оценки качества специальной одежды/ З.С. Чубарова. – М.: Легпромиздат, 1988. – 160 с.
- [13] Харлова О.Н. Методологические основы проектирования и формирования качества больничной одежды различного ассортимента: автореферат дис. ... д-ра техн. наук: 05.19.04 / О.Н. Харлова – Москва, 2011.
- [14] Сурикова Г.И. Проектирование изделий легкой промышленности в САПР (САПР одежды): учебное пособие / Г.И. Сурикова, О.В. Сурикова, В.Е. Кузьмичев, А.В. Гниденко. – М.: ИД «ФОРУМ»: ИНФРА-М, 2013. – 336 с.
- [15] Черемных С.В. Структурный анализ систем: IDEF – технологии / С.В. Черемных, И.О. Семенов, В.С. Ручкин. – М.: Финансы и статистика, 2001. – 208 с.
- [16] Цуканова О. А. Методология и инструментарий моделирования бизнес- процессов: учебное пособие/ О. А. Цуканова - СПб.: Университет ИТМО, 2015. – 100 с.
- [17] ГОСТ 2.103-2013 Единая система конструкторской документации (ЕСКД). Стадии разработки (с Поправкой).
- [18] Королева Л.А. Моделирование процессов интеллектуальной информационной системы «Художественное проектирование» в рамках интегрированной САПР одежды / Л.А. Королева, О.В. Панюшкина, А.В. Подшивалова и др.// Фундаментальные исследования. №9, 2014. – С. 18-23.
- [19] Подшивалова А.В. Реализация структурного подхода к проектированию интеллектуальной информационной системы «Технология швейных изделий» // А.В. Подшивалова, О.В. Панюшкина, Л.А. Королева // Фундаментальные исследования. №9 (часть 2), 2014. – С. 277-282.
- [20] Свидетельство о регистрации ПО № 2013620969. База данных методов технологической обработки верхней одежды поясной группы // Королева Л.А., Панюшкина О.В., Подшивалова А.В. Оpubл.: 21.08.2013
- [21] Свидетельство о регистрации ПО № 2013620833База данных методов технологической обработки верхней одежды плечевой группы // Королева Л.А., Панюшкина О.В., Подшивалова А.В. Оpubл.: 16.07.2013
- [22] Во ВГУЭС продемонстрировали одежду для маломобильных граждан Электронный ресурс: Режим доступа: http://www.vvvsu.ru/latest/article/2144890425/vo_vgues_prodemonstrirovali_odezhdu
- [23] Отправиться «За Синей птицей» помогут студенты-дизайнеры ВГУЭС Электронный ресурс: Режим доступа: http://www.vvvsu.ru/latest/article/2145198964/otpravitsya_za_siney_pticey
- [24] Патент на полезную модель № 165545. Юбка с фиксатором для женщин с ограниченными двигательными возможностями // Т.А. Зайцева, И.А. Слесарчук, О.Н. Данилова. Оpubл.: 20.10.2016 Бюл. № 29
- [25] Патент на полезную модель № 166971. Юбка с карманом для женщин с ограниченными двигательными возможностями // Т.А. Зайцева, И.А. Слесарчук. Оpubл. 20.12.2016. Бюл. № 35